

# KD-1 type

Available from 0.49Ton to 2Ton capacity



## KD-1 type

- Hoist classification : FEM(1Bm) / ISO(M3)
- Motor & brake class : "F" class
- Ambient temperature : -20°C ~ +40°C
- Intermittent Rating(%ED) :  
single speed(25%ED) / dual speed(20%ED)

- High class Slip clutch system
- DC brake system
- Emergency stop
- Powerful motor
- KD manufactured load chain

### I STANDARD SPECIFICATION

Model	Capacity (ton)	Lift (m)	Duty rating (min)		Lifting Speed (m/min)				Traversing Speed (m/min)		Load Chain Dia. (mm)	No. of Falls of Load Chain	Test Load (kg)
			Single	Dual	Single		Dual		50Hz	60Hz			
					50Hz	60Hz	50Hz	60Hz					
KD-1	0.49	4	30	5/15	6.7	8	6.7/1.7	8.0/2.0	-	-	φ7.1	1	613
	0.5	4	30	5/15	6.7	8	6.7/1.7	8.0/2.0	-	-	φ7.1	1	625
	1	4	30	5/15	6.7	8	6.7/1.7	8.0/2.0	-	-	φ7.1	1	1,250
	2	4	30	5/15	3.4	4	3.4/0.9	4.0/1.0	-	-	φ7.1	2	2,500
KD-1M	0.49	4	30	5/15	6.7	8	6.7/1.7	8.0/2.0	10, 20	12, 24	φ7.1	1	613
	0.5	4	30	5/15	6.7	8	6.7/1.7	8.0/2.0	10, 20	12, 24	φ7.1	1	625
	1	4	30	5/15	6.7	8	6.7/1.7	8.0/2.0	10, 20	12, 24	φ7.1	1	1,250
	2	4	30	5/15	3.4	4	3.4/0.9	4.0/1.0	10, 20	12, 24	φ7.1	2	2,500

Capacity (ton)	Output (kw)		Traversing (kw)	Net weight		Extra weight per 1m lift (kg)	
	Single	Dual		KD-1	KD-1M	KD-1	KD-1M
0.49	0.8	0.8/0.2	0.4	55 (57)	95 (97)	1.1	1.1
0.5	0.8	0.8/0.2	0.4	55 (57)	95 (97)	1.1	1.1
1	1.5	1.5/0.38	0.4	59 (61)	100 (102)	1.1	1.1
2	1.5	1.5/0.38	0.4	75 (77)	115 (117)	2.1	2.1

### I DIMENSION



Model	Capacity (ton)	Dimension (mm)											Std.I-Beam Width (mm)	Min. Radius of Curve (mm)
		A	B	C	D	E	F	H	S	W	P	G		
KD-1	0.49	258	265 (315)	132	132	-	29	-	-	40	663	450	-	-
	0.5	258	265 (315)	132	132	-	29	-	-	40	663	450	-	-
	1	258	308 (335)	132	132	-	29	-	-	40	663	450	-	-
	2	258	308 (335)	97	167	-	34	-	-	50	683	640	-	-
KD-1M	0.49	258	265 (315)	75	338	218	29	121	230	40	663	435	75,100,125	1,000
	0.5	258	265 (315)	75	338	218	29	121	230	40	663	435	75,100,125	1,000
	1	258	308 (335)	100	350	230	29	121	230	40	663	435	75,100,125	1,000
	2	258	308 (335)	125	363	243	34	123	296	50	667	670	100,125,150	1,500

( ) Dual speed Dimension, Specification

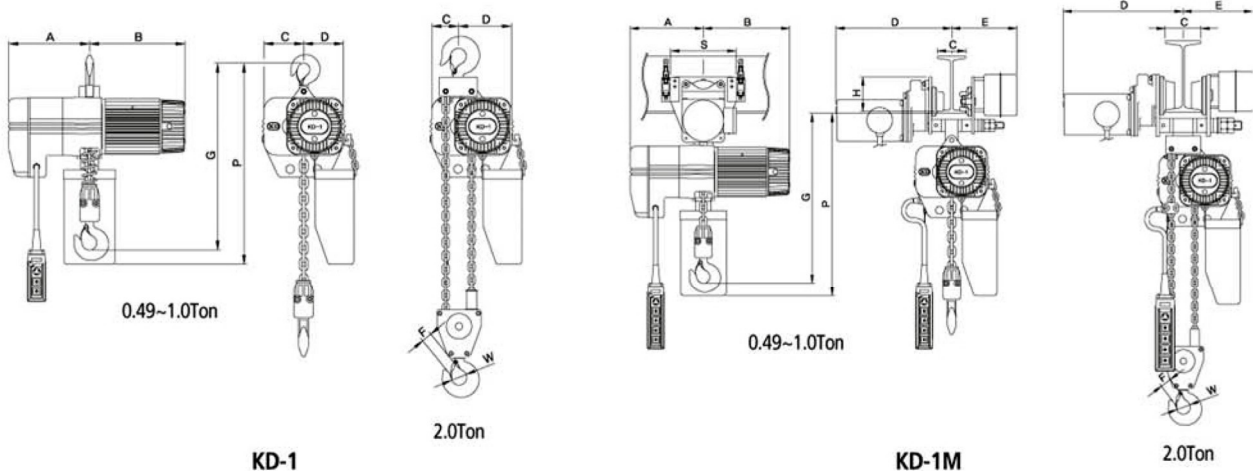

• The design, material and specification are subject to change for improvement without notice.  
 • A special specification is available upon request.  
 • 극동호이스트(주) 제품의 규격은 품질개선을 위하여 예고없이 변경될 수 있으므로 제품 구입시 문의바랍니다.

※ F 치수는 안전고리 제외된 치수임